

THIS DRAWING IS UNPUBLISHED. RELEASED FOR PUBLICATION  
 © COPYRIGHT BY TYCO ELECTRONICS CORPORATION. ALL RIGHTS RESERVED.

LOC	DIST	REVISIONS					
FT	0	P	LTR	DESCRIPTION	DATE	DWN	APVD
			F1	REVISED PER ECO-07-017618	7/31/07	SS	MS

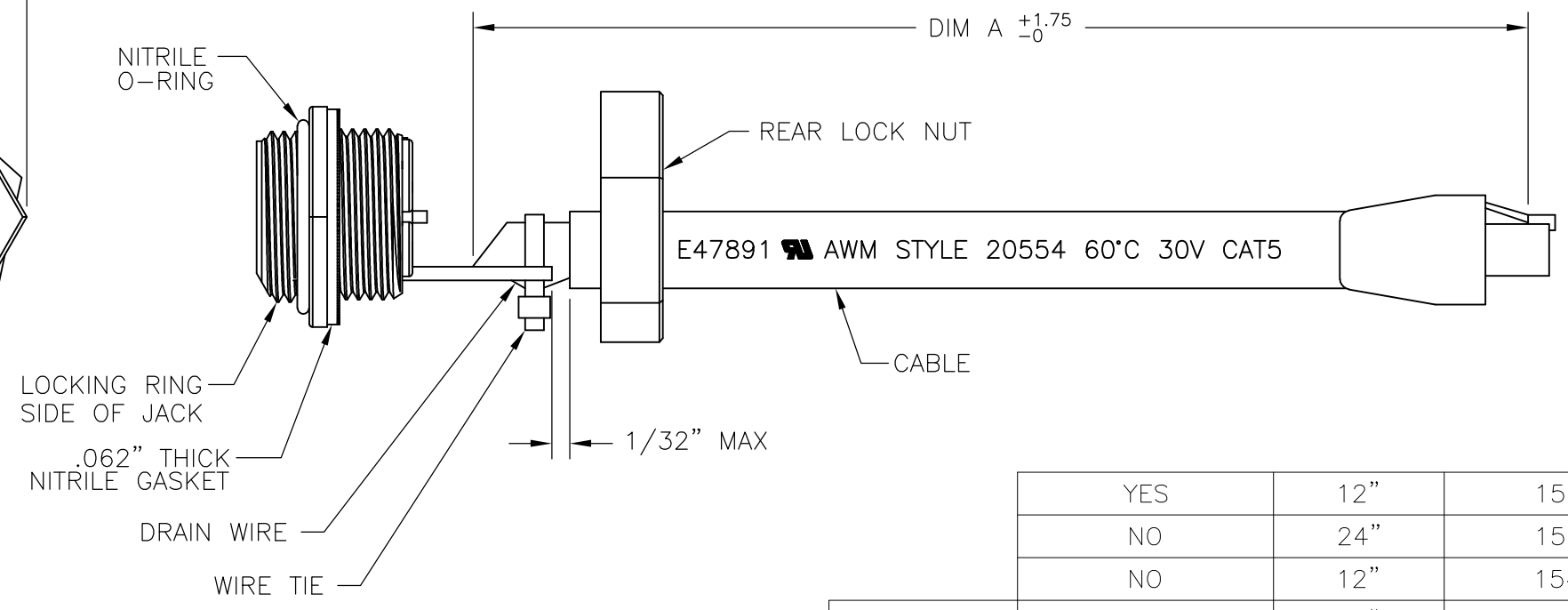
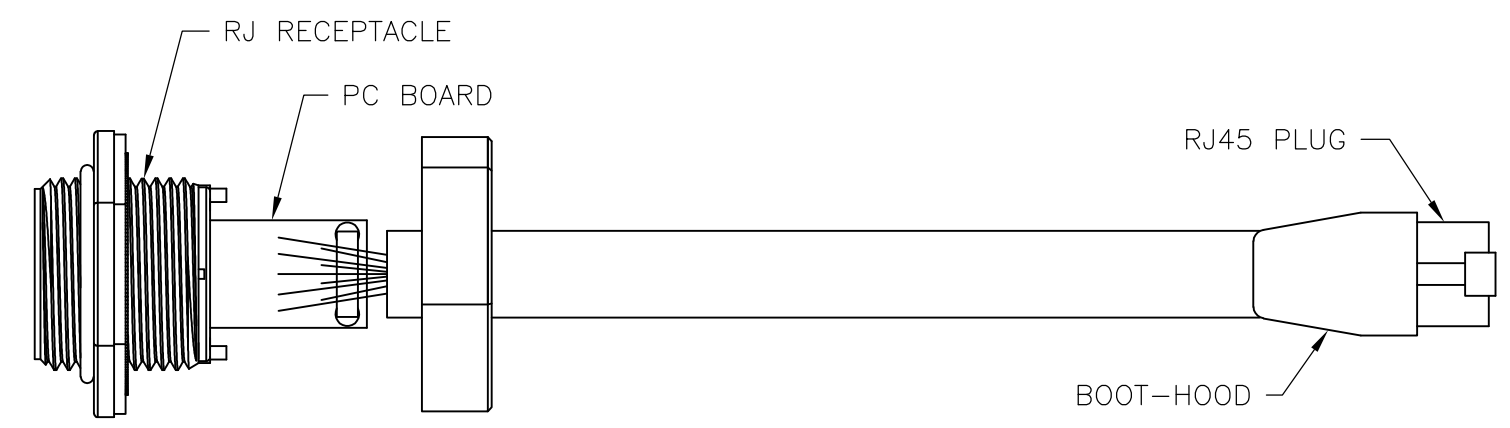
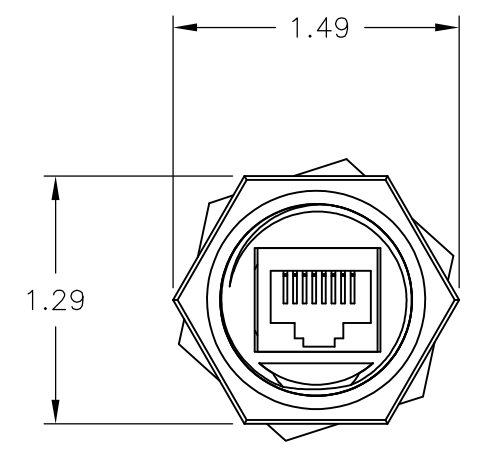
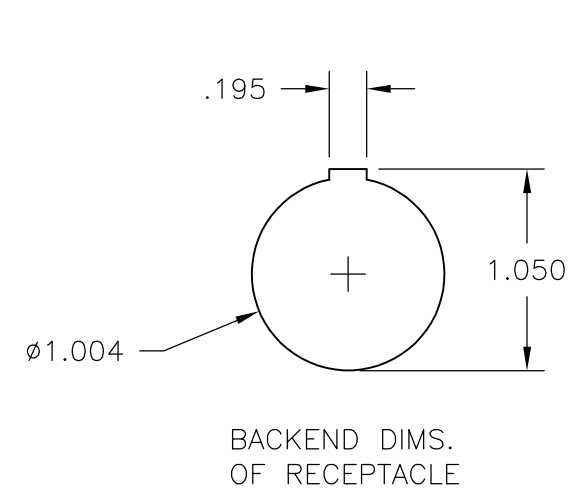

WIRE LIST	
PIN (SAME FOR BOTH CONNECTORS)	
1	WHT/BLU
2	BLUE
3	WHT/ORG
4	GREEN
5	WHT/GRN
6	ORG
7	WHT/BROWN
8	BROWN
GRND	

YES	12"	1546414-6	
NO	24"	1546414-5	
NO	12"	1546414-4	
SUPERSEDED	YES	12"	1546414-3
SUPERSEDED	NO	24"	1546414-2
SUPERSEDED	NO	12"	1546414-1
	CABLE TIE	DIM A	PART NUMBER

**MATERIALS:**  
 BOOT-HOOD: POLYOLEFIN, BLACK.  
 JACK: CAT 5E PCB.  
 LOCKNUT: ABS, 10% GLASS FILLED, BLACK.  
 PANEL MOUNT HOUSING: CLCOLAC  
 CABLE: 26 AWG 8 CONDUCTOR BLACK PVC JACKET.

THIS DRAWING IS A CONTROLLED DOCUMENT.		DWN	S SCHLEGEL	09OCT2002	Tyco Electronics Corporation Harrisburg, PA 17105			
DIMENSIONS: INCHES		CHK	H WAKEEM	10/9/02	NAME			
TOLERANCES UNLESS OTHERWISE SPECIFIED:		APVD	H WAKEEM	10/9/02	ETHERNET PANEL MOUNT RECEPTACLE RJ-45 BULKHEAD PASS THROUGH WITH PATCH CORD			
0 PLC ± -		PRODUCT SPEC		SIZE		CAGE CODE	DRAWING NO	RESTRICTED TO
1 PLC ± -		APPLICATION SPEC		A3		00779	G-1546414	-
2 PLC ± .02		MATERIAL		CUSTOMER DRAWING		SCALE	SHEET	REV
3 PLC ± .005		FINISH		SCALE		NTS	1 OF 1	F1
4 PLC ± -								
ANGLES ± 2'								